

Biological Safety Cabinet, NSF/ANSI 49 Certified



BSC-1301IIA2/1302IIA2



Airtech Biological safety cabinet Class IIA2 recirculates 70% of the HEPA-filtered laminar air and 30% passes through an exhaust HEPA filter for discharge, providing the protection to person, samples and environment from biological hazards and contamination.

DC ECM motor saves 60% energy compared with traditional AC motor.

Downflow and exhaust HEPA (H14) filter efficiency is 99.995%@0.3 μ m and conforms to EU standard EN1822.

Velocity displays accuracy at 0.001m/s.

The Biosafety cabinets are NSF/ANSI49 certificated.



ECM DC brushless motor for stable and durable running and energy saving

HEPA (H14) Filter ,
99.995% efficiency for partical size 0.3um

Intellegnet controller with Color LCD Display
easy viewing display of working status and operation



LED lamp providing sufficient and uniform lighting; UV lamp with timer and it Interlocked with LED lamp and sash window for convenient and safet decontamination

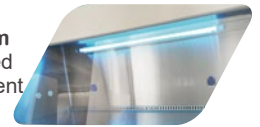

2 Waterproof power sockets

One piece of SUS304 sheet and with round corner in work zone, no leakage piont and easy for cleaning
The table is made of stainless steel 304 and can be lifted with support and taken out.



Tempered sash glass, 6mm thickness security glass, high stability and anti-UV,

Pressure gaugue
USA Dwyer brand accuracy indicates realtime negative pressure



Removable spill retaining table top with front grille, curved corners made in SUS304 , easy for cleaning

Durabel Casters for easy moving

Height adjustable support stand to make sure cabinet is set firmly and horizontally



International Standards

	Biosafety Cabinets	Air Quality	Filtration	Electrical Safety
Standards Compliance	Designed to meet: NSF/ ANSI 49 (USA)	ISO 14644.1, Class 5, Worldwide JIS B9920, Class 5, Japan JIS BS5295, Class 5, Japan US Fed Std 209E, Class 10 USA	ISO29463, Worldwide EN-1822, Europe EN13091, Europe IEST-RP-CC034.1, USA	UL61010-1, USA CAN/CSA-22.2, No.61010-1



Biosafety cabinet air pattern

Approx. 30% air exhausted
 Approx. 70% recirculated through downflow
 Inflow air creates an air barrier to protect the inside air leakage to room and room air entry into Work zone.

- 1 Downflow HEPA filter
- 2 Exhaust HEPA filter

- Room air
- Contaminated air
- HEPA filter downflow air
- HEPA filter exhaust air

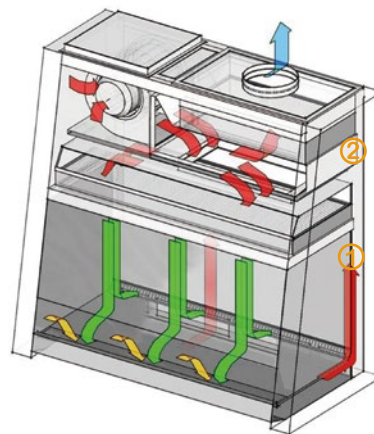

Reliable ECM DC brushless motor Intelligent CAV technology(Constant Air Volume) and CPAS (Constant Pressure Apheresis System) technology

The biological safety cabinet adopts the USA Genteq brand ECM DC brushless motor working with the CPAS and CAV technology providing a safe and reliable airflow volume and pressure during the operation in BSC.

Based on ECM feature, it can determine supply air volume and pressure by detecting changes in internal current and power, and can realize automatic regulation on the balance of air volume or pressure. The CPAS and CAV technologies are to precisely control airflow.

It automatically maintains constant airflow during filter loading or temporary obstruction.

The intelligent technology ensures the change of air volume less than 10% when the resistance of filter increases 50% and enhance safety.



Reliable Filtration System

The HEPA (H14) filters of downflow and exhaust with filtration efficiency $\geq 99.995\%$ for 0.3micron particles according with EN13091:1999 and EN 1822-1standard, and designed with the leakage resistance patent technology.

The medium of two HEPA filters is USA H&V brand.

The air cleanness in workzone is Class 5 (ISO14644.1 standard) .

Unique ECO Mode for energy saving

Under ECO Mode, the blower runs in low speed. It reduces the switch off/on time and saves time for self-purification, UV disinfection. It is 80% energy saving.

- Manual control type: Press ECO button, it switch to ECO mode.
- Automatically entry into ECO mode, after sash window shut down, and 5s sound and light alarm delay, the biosafety cabinet enters into ECO mode automatically. When the sash is open, the blower returns to normal quickly.



Intelligent control system

The Intelligent microprocessor controller with color LCD display and soft buttons are convenient to observe BSC working status. Password protection avoids unauthorized change on operating parameters.

Color LCD display content

- Blower, LED light, UV light and socket works icons are clearly shown
- Downflow velocity and inflow velocity display accuracy is 0.001m/s,
- Filter life shows in percentage, it reminds user to change the filter in time.
- Time display is easy to know the operation time
- UV timer and UV time

Alarm function	Inflow velocity alarm	✓
	Downflow velocity alarm	✓
	Blower failure alarm	✓
	Sash limited height alarm	✓
	Filter life alarm	✓

Color LCD display

Display realtime work condition performance includes the inflow velocity, downflow velocity, filter life, system condition and time etc.

Soft press button

Control the blower, UV light, LED light and socket and buzzer alarm mute
Light indicator light is easy for observing the button condition



ECO mode

Press the ECO button, BSC entries into energy saving mode.

Programmable UV disinfection

254nm UV germicidal light with safety interlocked with LED light and anti-UV sliding sash window, enables work zone operate UV disinfection and protects operator in safety.

The standard UV timer can be set according the enhanced disinfection control, prolong the UV lamp life and saving energy.

- UV light automatically turns off delay 0~999 minutes programmable with 1 minutes increment.
- UV light automatically On/Off is 00:01 to 23:59 programmable with 1 minutes increment

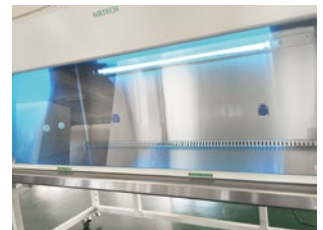

Excellent Designed parts

10° angled front exceptional comfort for operation in work zone.

Anti-UV sliding sash glass with thickness, high stability and convenient to UV sterilization when it closed.

Spring lifting system applies in Front sash window can make glass height level at arbitrary positioning, and avoids sash glass drop down suddenly.

Removable work table is made of SUS304 and can be took out from work zone. It can be risen up by handle and support rod, convenient for clean the below area.

Interior is made by one piece of SUS304 plate with round corner, no welding point, no leakage risk and easy for cleaning.

Anti-bacteria powder coated Exterior body is easy for cleaning.

Water collecting tank with drainage valve, easy to collect water, cleaning and disinfection liquid.

Height adjustable support base stand is quipped with mobile castors and leveling feet. (table height 780~980mm optional table height 700~800mm height)

Accessories

2 power sockets are reserved on right and left of interior back wall, it is easy for operator to use small device in BSC.

LED light and UV lamp are standard Installed.

Remote Dry contact enable user know the biosafety cabinet power on or off in remote distance.

Test service ports are reserved. Blower positive pressure test port and negative pressure port are convenient for engineer to test the biosafety cabinet condition

Optional Canopy kits

HEPA filters have ability to trap particles and biohazards.If your work includes the use of volatile organic solvents,gases, or vapors which can not be trapped by filters. it is important to choose canopy and an exhaust duct to route exhaust air out of the laboratory. We supply two different canopies.

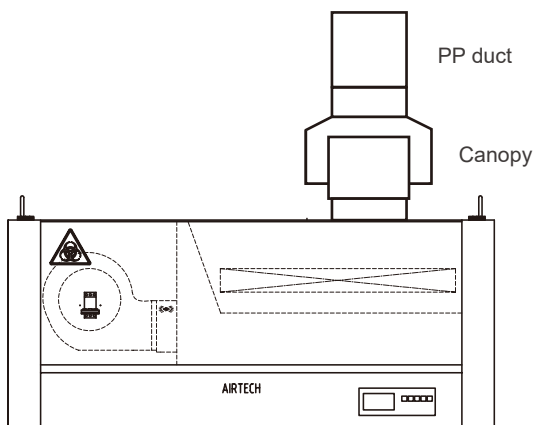

Canopy simple type, Exhaust air volume depend on external blower

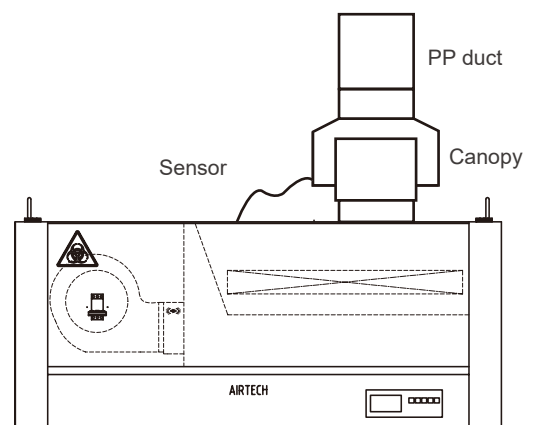

Canopy with velocity sensor and connects with BSC, more safe to monitor exhaust air condition.

Class II Type A2 Biological Safety Cabinet Engineering Drawing

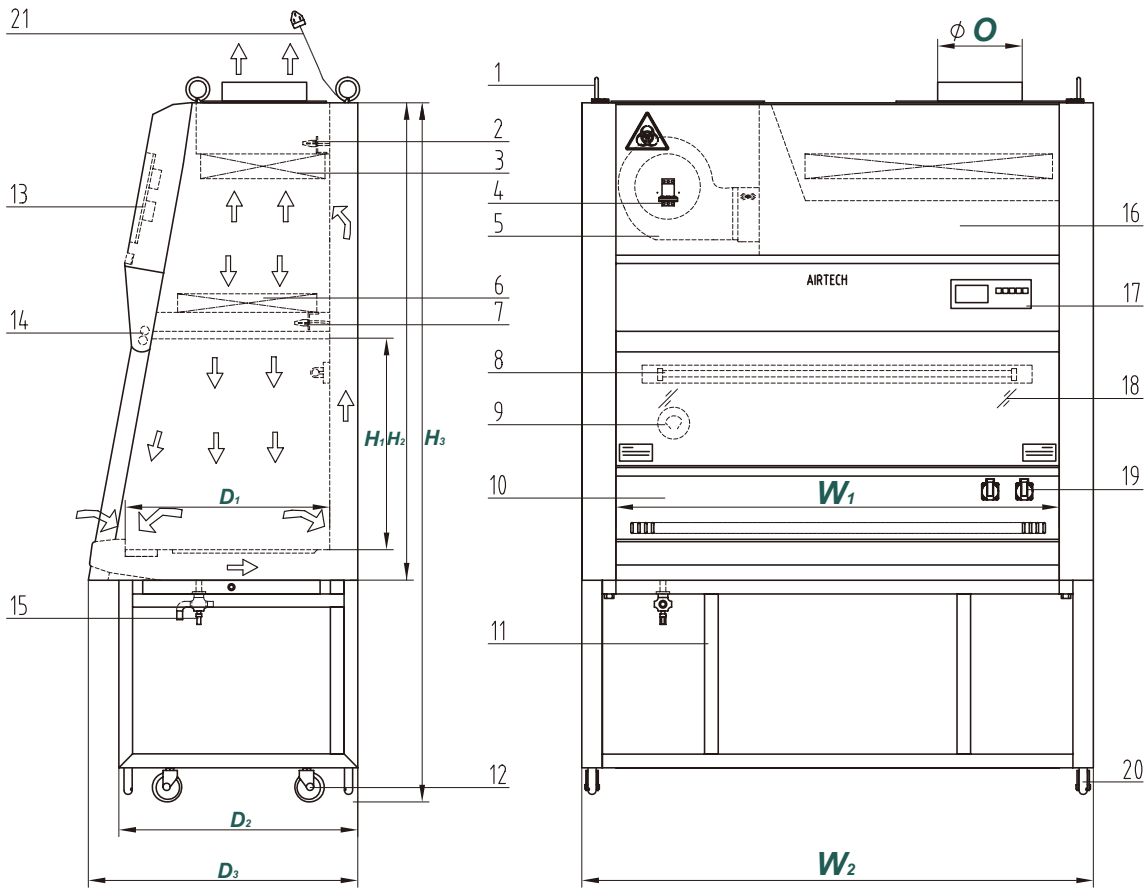

- | | | |
|-----------------------------|----------------------------|---|
| 1. Eyebolt | 2. Exhaust velocity sensor | 3. Exhaust HEPA filter |
| 4. DC motor fan | 5. Main power switch | 6. Downflow HEPA filter |
| 7. Downflow velocity sensor | 8. UV lamp | 9. US brand dwyer differential pressure gauge |
| 10. Work area | 11. Detachable stand | 12. Universal casters |
| 13. Main power board | 14. LED lamp | 15. Drain valve |
| 16. Main body | 17. Control panel | 18. Glass door |
| 19. Sockets | 20. Adjustable feet | 21. Power cord |

Model	Dimensions in mm								
	W_1	W_2	D_1	D_2	D_3	H_1	H_2	H_3	O
BSC-1301IIA2	1270	1500	600	700	790	620	1490	2050	250
BSC-1302IIA2	1270	1500	600	700	790	620	1490	2050	250

TECHNICAL SPECIFICATIONS

Model		BSC-1301IIA2	BSC-1302IIA2
Dimensions	Nominal Size	4 feet	
	Work Table Height (mm)	700 (mm)	
	Internal (W x D x H)	1270*600*620 (mm)	
	External (W x D x H)	1500*790*2050 (mm)	
	Plywood Packing (W x D x H)	1600*1070*1590 (mm)	
Airflow	Type	Class II, Type A2	
	Exhaust Direction	Top Exhaust	
	Airflow Pattern (downflow / exhaust)	70% / 30%	
	Average Inflow Velocity	69fpm	
	Average Downflow Velocity	106fpm	
	Inflow Airflow Volume	617 m ³ /h	
	Downflow Airflow Volume	896 m ³ /h	
	Exhaust Airflow Volume	617 m ³ /h	
	Velocity Meter Accuracy	0.001m/s	
	Pressure Gage	Dwyer Brand, USA	
Construction	Blower	ECM DC Motor	
	Work Zone	SUS304, Single-piece(3-pieces optional)	
	Main Body	Electro-galvanized steel with white powder-coated finish	
	Sash Glass Thickness	6mm	
	Sash Glass Type	Tempered Glass, UV-proof	
	Sash Window Working Opening	250 (mm)	
	Sash Window Maximum Opening	480 (mm)	
	Illumination (Lx)	≥1000	
Noise (dB)	≤67		
Cleanliness	Air Cleanliness	HEPA: ISO Class 5	
	Filtration Efficiency	HEPA: ≥99.995%, @0.3 μm	
	Total colony in impaction sampler(Operator Protection)	≤10CFU./Time	
	Total colony in slit type sampler(Operator Protection)	≤5CFU./Time	
	Total colony in culture dish (Product Protection)	≤5CFU./Time	
Controller	Total colony in culture dish (Cross Contamination)	≤2CFU./Time	
	Display	LCD Screen	
	UV Timer	Yes	
	Main Power Switch	Yes	
Electrical Data	Key Switch	Yes	
	Power Consumption (KW.h/h)	0.6	
Power Supply	Power (W)	540	
	Voltage	115V/60Hz	230V/50Hz
Weight	Net Weight(kg)	300	
	Gross Weight, Plywood Packing (kg)	405	
Alarm	Alarm Type	visible and audible	
	Inflow Velocity	Yes	
	Downflow Velocity	Yes	
	Sash Height Limit	Yes	
	Filter Lifetime Remind	Yes	
Filter	Downflow	HEPA: ≥99.995%, @0.3 μm	
	Exhaust	HEPA: ≥99.995%, @0.3 μm	
	Material	HV Brand, USA	
Accessories	Side Wall	SUS304/Glass	
	Front Sash	Manual	
	LED Lamp	24.5Wx2, ≥1000Lx	
	UV Lamp	15Wx2	
	Receptacle (pieces/Power/Current)	2pcs/500W/2A	
	Detachable Stand	Optional	
	Adjustable Foot	Yes	
	Wheels	Yes	
	Gas Valve	Optional	
	Vacuum Valve	Optional	
	Arm Rest	Optional	
I.V. Pole	Optional		

